

# Air Loaded Rotational Type Dancer Roll Assemblies

*Ideal for all web processing operations:  
textiles, plastics, paper, film, etc.*

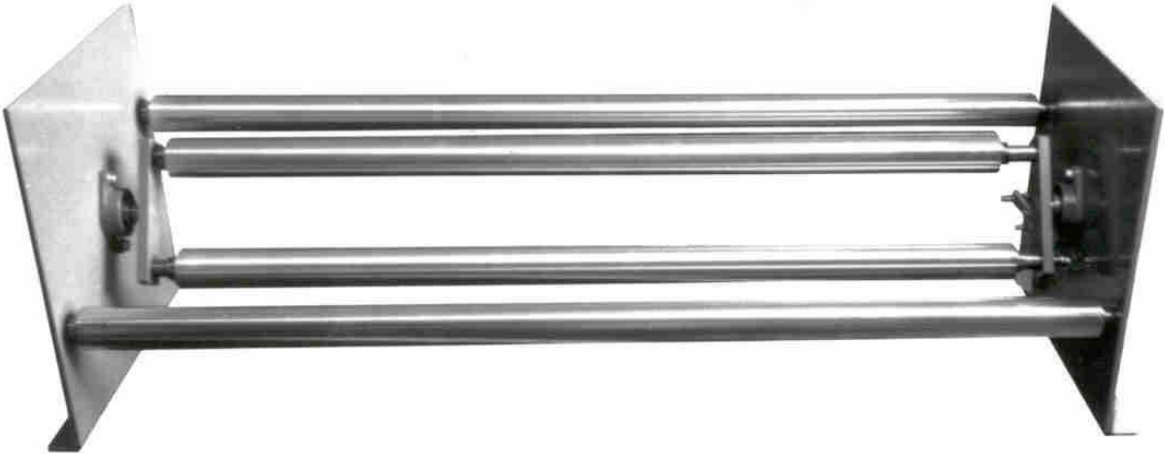

## Features and Benefits include:

- Automatically counterbalanced for maximum control performance
- Maximum stability
- Simple control circuit
- Large material storage
- Accommodates a wide range of web widths
- Electrically and/or pneumatically operated clutches, brakes and drive motors
- Lead-in and lead-out idlers
- Self-contained, free standing design
- Cantilevered mounting available for narrow width applications
- Air or mechanical loading
- Constructed of structural steel weldments for maximum strength and rigidity
- Ideal for all web-fed converting equipment
- Well suited for all types of web materials – paper, film, foil, plastic, nonwovens, textiles, etc.
- Can be used to advantage in either unwind or rewind applications
- Designed to exact customer requirements – easily retrofits to existing web lines and equipment



Web Handling Technology . . . CAC Engineered and Manufactured

**CONVERTER ACCESSORY CORP.**

[www.handleyourweb.com](http://www.handleyourweb.com)  
Email: [cac@epix.net](mailto:cac@epix.net)

PHONE: 800-433-2413  
610-863-6008

FAX: 800-709-1007  
610-863-7818

# Air Loaded Rotational Type Dancer Roll Assemblies

Designed and manufactured by CAC

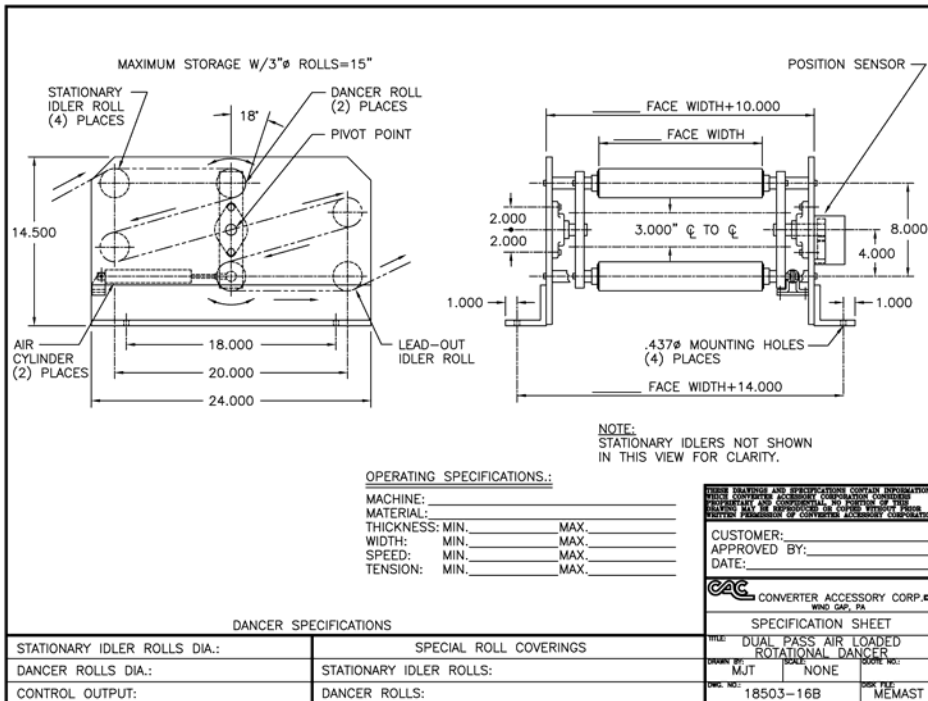
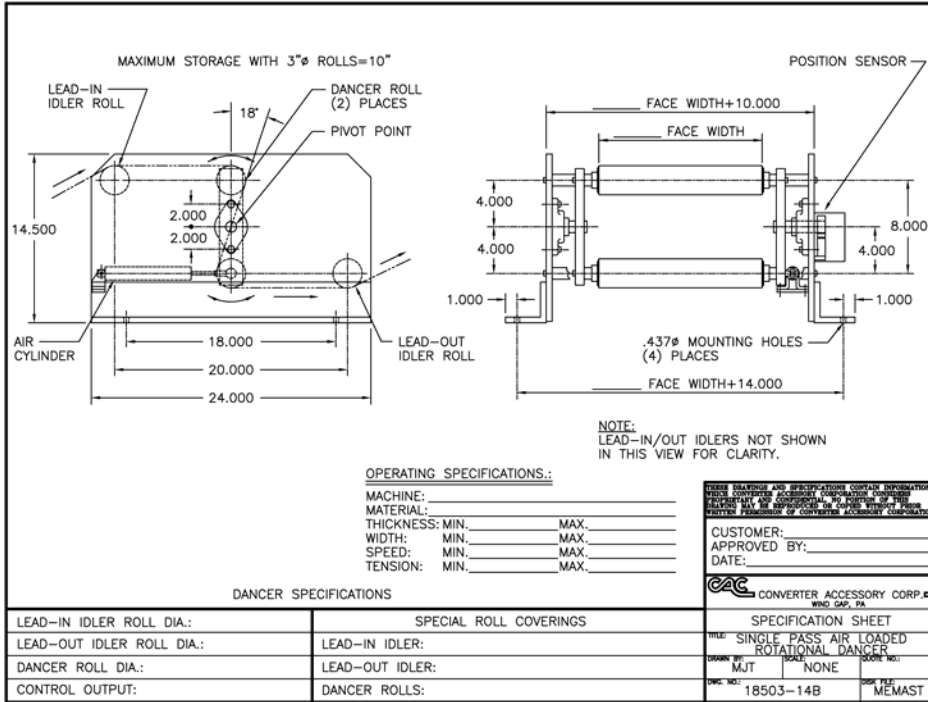

Web Handling Technology . . . CAC Engineered and Manufactured

**CONVERTER ACCESSORY CORP.**

[www.handleyourweb.com](http://www.handleyourweb.com)  
Email: [cac@epix.net](mailto:cac@epix.net)

PHONE: 800-433-2413  
610-863-6008

FAX: 800-709-1007  
610-863-7818