

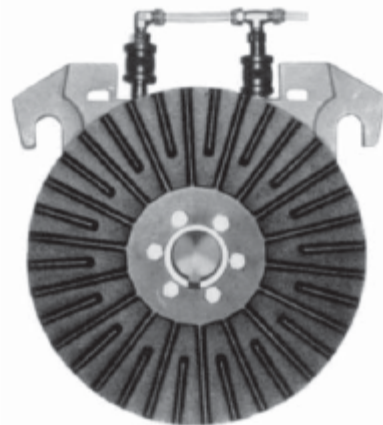

# Tension Brakes

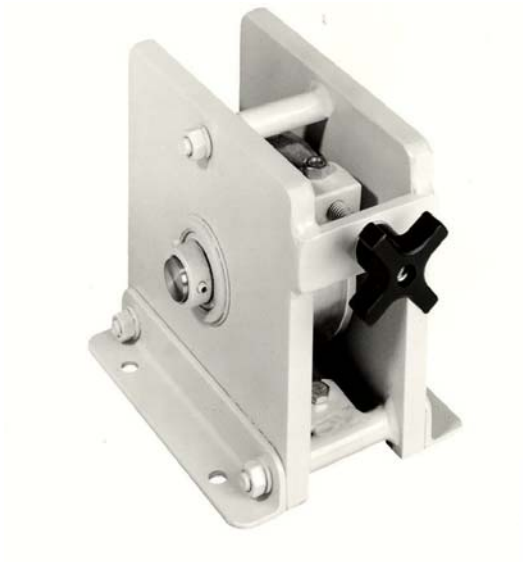

# Air Operated Tension Brake

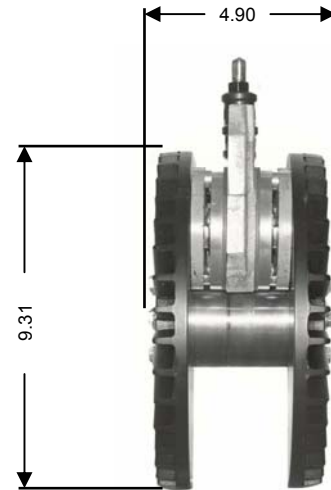

## Torque

6000 Series	.10 Pads		.30 Pads		.45 Pads	
	Lb. In.		Lb. In.		Lb. In.	
Model	Max	Min	Max	Min	Max	Min
62__	330	2.2	1100	6.6	1500	10
(Pad Value)					3000	
64__	660	2.2	2200	6.6	3000	10
(Pad Value)					3000	

## Horse Power (Heat Dissipation)

600	2.87	1250	4.63	1900	6.00
550	2.72	1200	4.51	1850	5.90
500	2.56	1150	4.39	1800	5.81
450	2.40	1100	4.26	1750	5.71
400	2.23	1050	4.14	1700	5.61
350	2.06	1000	4.01	1650	5.51
300	1.89	950	3.88	1600	5.41
250	1.72	900	3.74	1550	5.31
200	1.54	850	3.60	1500	5.20
150	1.36	800	3.46	1450	5.09
100	1.18	750	3.32	1400	4.98
50	0.99	700	3.17	1350	4.87
0	0.80	650	3.02	1300	4.75
ECS	HP	ECS	HP	ECS	HP

- Simple design
- Easy to operate
- Broad torque range
- Three friction coefficients to choose from
- Select 2, 4, 6 or 8 friction pad engagement for proper torque for your unique setups
- Accepts variable air pressure to vary the torque
- High heat dissipation
- Manufactured in the USA
- Thru bore brake - bore sizes up to 1.750" available
- Easily combined with CAC ShaftLok™ safety shaft holders or SimpLok™ shaft holders for complete unwind upgrades

Save time! Calculate your torque and horsepower requirements at <http://www.converteraccessory.com/ss/tqrpmhp.htm> !\*\*

You will need the following information for the calculator:

- Roll outside diameter
- Core diameter
- Maximum running speed in feet per minute
- Minimum running speed in feet per minute
- Maximum web tension in pounds per linear inch
- Minimum web tension in pounds per linear inch
- Maximum web width
- Minimum web width
- Maximum roll weight
- Stop time (if you want to calculate emergency stop torque)

**\*\*DISCLAIMER**—A great deal of time has been invested in the development, testing and debugging of our online calculators. To the best of our knowledge, they are free of defects. It is up to the user to verify all results presented by our calculators.

The author assumes no liability connected with the use of this information or the results obtained from it.



Ball bearing



Bronze bushing

## Features and Benefits:

- Simple rugged construction—virtually maintenance free
- Accommodates shaft sizes of 3/4", 7/8", 1", 1-1/8", 1-1/4"
- Manufactured in the USA
- Shipped fully assembled and ready for installation
- Easily combines with CAC ShaftLok™ safety shaft holders or SimpLok™ shaft holders for complete unwind upgrades



Tried, tested and reliable products for the web-fed industry

- Air shafts and chucks - [www.cor-lok.com](http://www.cor-lok.com)
- Pneumatic trim and matrix removal systems  
[www.foxtrimaway.com](http://www.foxtrimaway.com)
- Shaft support systems - [www.simplok.com](http://www.simplok.com)
- Wrinkle removal systems - [www.cacwrinklestop.com](http://www.cacwrinklestop.com)
- Unwind / rewind systems  
[www.converteraccessory.com/products/roll\\_support](http://www.converteraccessory.com/products/roll_support)
- Modular slitting systems  
[www.converteraccessory.com/products/slitting](http://www.converteraccessory.com/products/slitting)
- Brakes and clutches  
[www.converteraccessory.com/products/related/brake](http://www.converteraccessory.com/products/related/brake)
- Roll Handling  
[www.converteraccessory.com/products/roll\\_lifting](http://www.converteraccessory.com/products/roll_lifting)
- Dancer Roll Assemblies  
[www.converteraccessory.com/products/dancer](http://www.converteraccessory.com/products/dancer)
- Slitting - [www.converteraccessory.com/products/slitting](http://www.converteraccessory.com/products/slitting)
- Idlers - [www.converteraccessory.com/products/related/mainidler](http://www.converteraccessory.com/products/related/mainidler)
- Custom Equipment  
[www.converteraccessory.com/products/related](http://www.converteraccessory.com/products/related)

Visit us at [www.converteraccessory.com/salesrep](http://www.converteraccessory.com/salesrep)  
for your local sales representative or  
contact us direct

**CONVERTER ACCESSORY CORPORATION**

201 Alpha Road, Wind Gap, PA 18091-1279

[www.converteraccessory.com](http://www.converteraccessory.com)

Email: [cac@epix.net](mailto:cac@epix.net)

●800-433-2413    ●610-863-6008  
●800-709-1007    ●610-863-7818 FAX

Web Handling Technology . . . CAC Engineered and Manufactured