



# TECHNICAL BULLETIN NO. 190

## CONVERTER ACCESSORY CORPORATION

201 Alpha Road, Wind Gap PA 18091

www.handleyourweb.com E-mail: cac@epix.net

Phone: 800-433-2413 or 610-863-6008

Fax: 800-709-1007 or 610-863-7818

## AIR LOADED NIP ROLL ASSEMBLIES

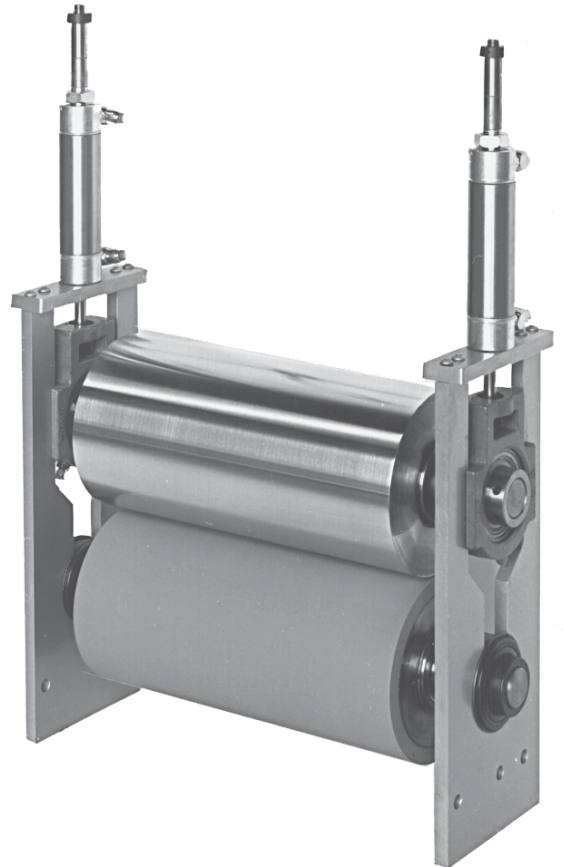

### FEATURES AND BENEFITS:

- Designed to exact customer specifications
- Utilizes precision air regulators and cylinders
- Designed for all types of materials
- Accommodates a wide range of roll diameters and web widths
- Available in a variety of roll finishes
- Can be supplied with drive system
- Ideal for all web-fed converting equipment
- Easily retrofits to existing web lines & equipment
- Cantilevered mounting available for narrow width applications
- Constructed of structural steel weldments for maximum strength and rigidity

# AIR LOADED NIP ROLL ASSEMBLIES

DESIGNED AND MANUFACTURED BY CAC

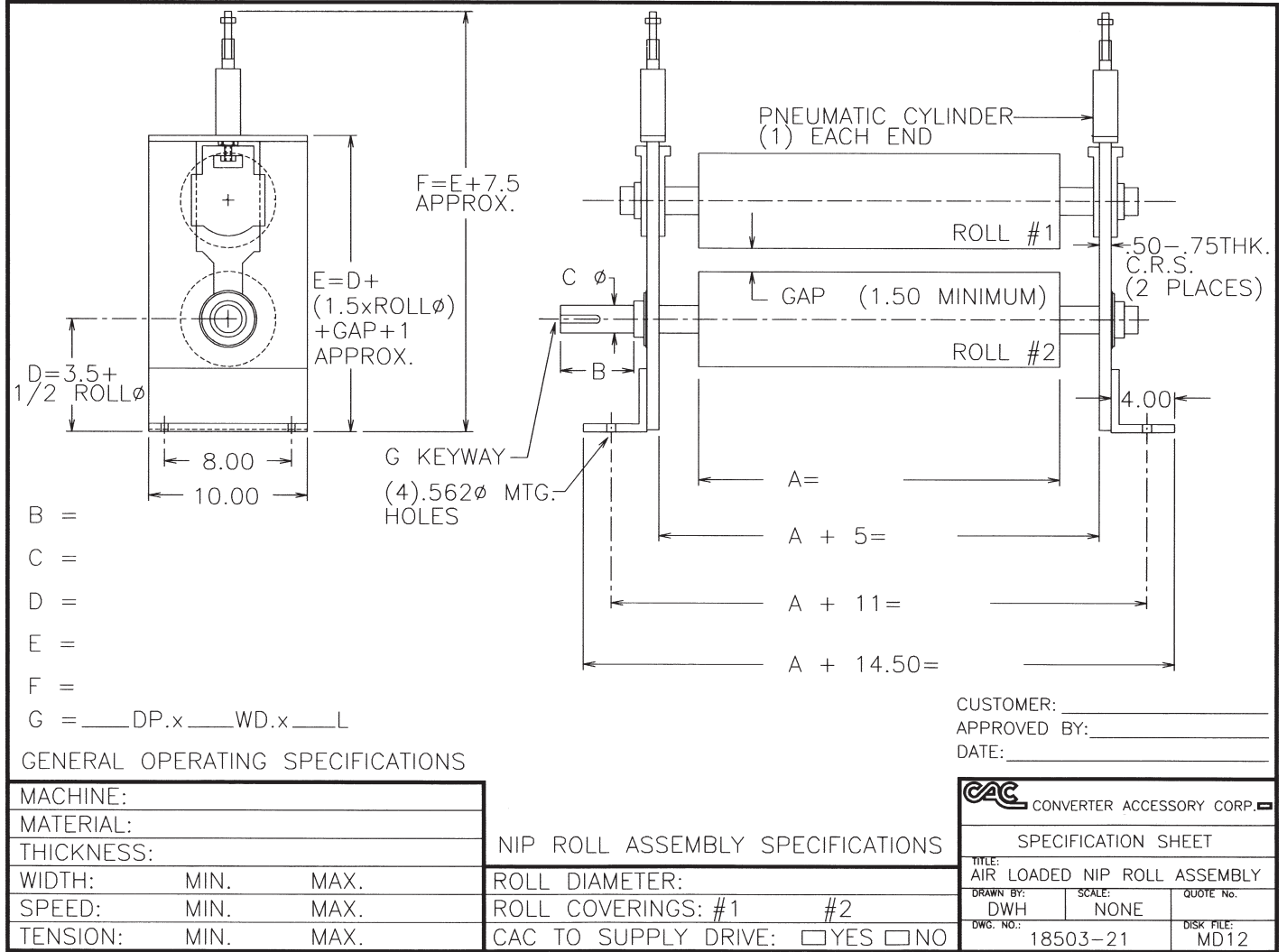

## CAC:

Tried, tested and reliable products for the web-fed industry

- Core Support Systems
- Shaft Support Systems
- Wrinkle Removal Systems
- Unwind/Rewind Systems
- Modular Slitting Systems
- Brakes & Clutches
- Pneumatic Trim & Matrix Removal Systems
- Accumulators



**Web Handling Technology...**  
**CAC Engineered & Manufactured**  
**CONVERTER ACCESSORY CORPORATION**

201 Alpha Road, Wind Gap PA 18091  
 www.handleyourweb.com E-Mail: cac@epix.net  
 Phone: 800-433-2413 or 610-863-6008  
 Fax: 800-709-1007 or 610-863-7818