

2

1

PARTS LIST

REVISION HISTORY

ITEM	QTY	PART NUMBER	DESCRIPTION
1	1	27609-20B	PLAIN BUSHING
2	1	27609-21B	SPLIT BUSHING
3	1	27609-29E	LOCKING SEGMENT
4	1	27609-43	3"DIA. REMOVABLE END CAP
5	1	27609-125	3"CLAC/CLAS-B2 BODY
6	10	27609-28D	RELIEF SEGMENT
7	1	27609-104	BUSHING PIN VALVE END
8	1	27609-106	BUSHING PIN PLAIN END
	3	27609-105	SET SCREW
10	1	27609-162	INFLATING TUBE
11	2	27609-90D	TAB CLAMP
12	2	27609-101C	CAP SCREW
13	1	31486-28	10-32 TAPPED BODY WITH EXTENSION
14	1	31486-18	RUBBER INFLATING TUBE PLUG
15	1	27609-107	SET SCREW
16	1	27609-01D	VALVE END CAP

ZONE	REV	DESCRIPTION	DATE	APPROVED
2B	A	INFLATING TUBE PART# WAS 27609-95B CAP SCREW PART# WAS 27609-101B REMOVED HELICAL INSERT PART#27609- 94A	5/16/17	MJT

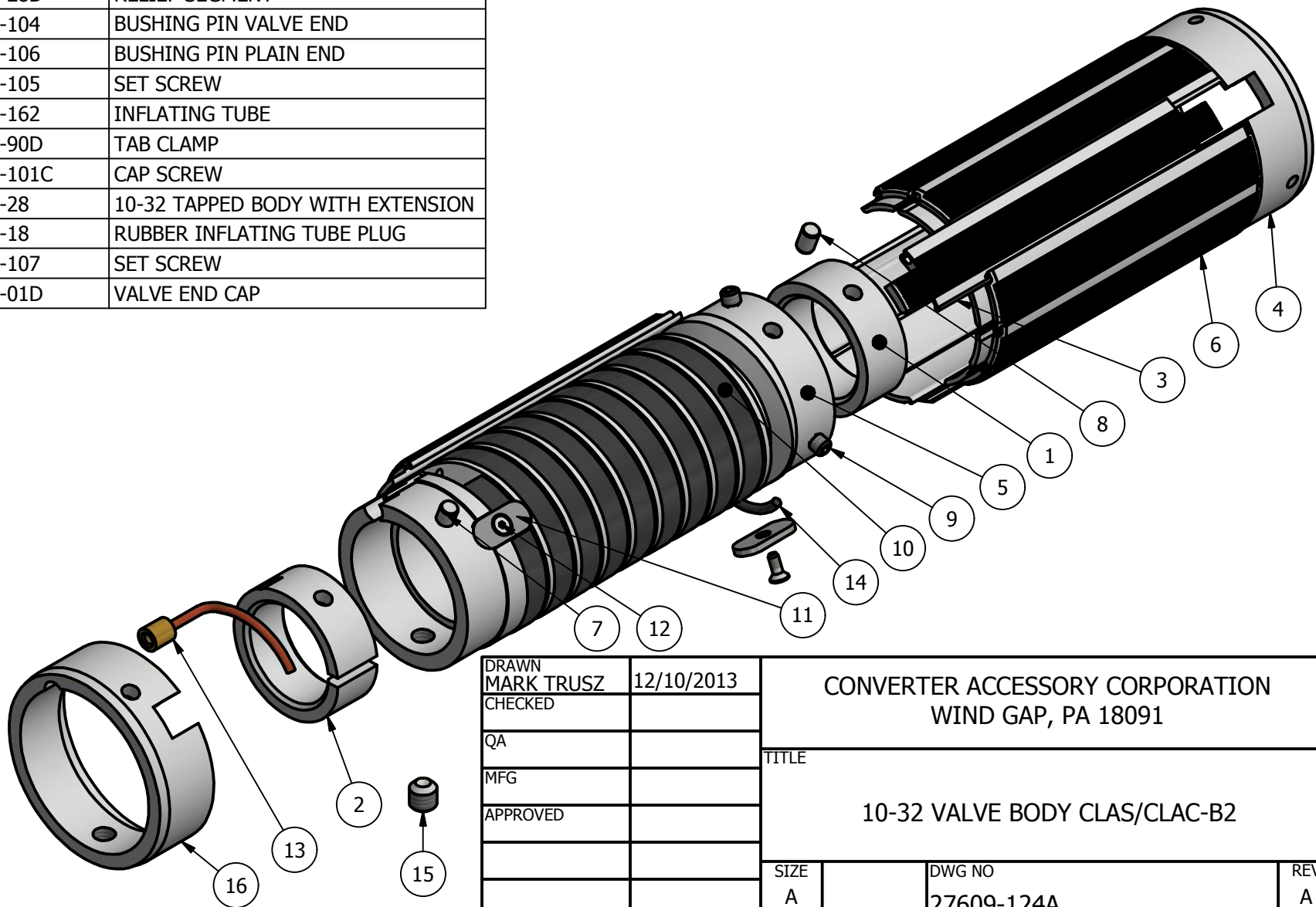

DRAWN	MARK TRUSZ	12/10/2013
CHECKED		
QA		
MFG		
APPROVED		

CONVERTER ACCESSORY CORPORATION WIND GAP, PA 18091		
TITLE 10-32 VALVE BODY CLAS/CLAC-B2		
SIZE	DWG NO	REV
A	27609-124A	A

2

1